

Features

- No External Components Except PIN Diode
- Supply-voltage Range: 4.5V to 5.5V
- High Sensitivity Due to Automatic Sensitivity Adaption (AGC) and Automatic Strong Signal Adaption (ATC)
- High Immunity Against Disturbances from Daylight and Lamps
- Small Size and Innovative Pad Layout
- Available for Carrier Frequencies between 33 kHz to 40 kHz; Adjusted by Zener Diode Fusing
- TTL and CMOS Compatible
- Suitable Minimum Burst Length ≥ 10 Pulses/Burst

Applications

- Home Entertainment Applications
- Home Appliances
- Remote Control Equipment

1. Description

The IC ATA2525 is a complete IR receiver for data communication that was developed and optimized for use in carrier-frequency-modulated transmission applications. The IC combines small size with high sensitivity as well as high suppression of noise from daylight and lamps. An innovative and patented pad layout offers unique flexibility for assembly of IR receiver modules. The ATA2525 is available with standard carrier frequencies (33, 36, 37, 38, 40 kHz) and 3 different noise suppression regulation types (standard, lamp, noise) covering requirements of different high-volume remote control solutions (please refer to selection guide available for ATA2525/ATA2526). The ATA2525 operates in a supply voltage range of 4.5V to 5.5V.

The function of ATA2525 can be described using the block diagram (see [Figure 1-1 on page 2](#)). The input stage meets two main functions. First, it provides a suitable bias voltage for the PIN diode. Secondly, the pulsed photo-current signals are transformed into a voltage by a special circuit which is optimized for low-noise applications. After amplification by a **Controlled Gain Amplifier (CGA)**, the signals have to pass a tuned integrated narrow bandpass filter with a center frequency f_0 which is equivalent to the chosen carrier frequency of the input signal. The demodulator is used to convert the input burst signal into a digital envelope output pulse and to evaluate the signal information quality, i.e., unwanted pulses will be suppressed at the output pin. All this is done by means of an integrated dynamic feedback circuit which varies the gain as a function of the present environmental condition (ambient light, modulated lamps etc.). Other special features are used to adapt to the current application to secure best transmission quality.



IR Receiver
ASSP

ATA2525



Figure 1-1. Block Diagram

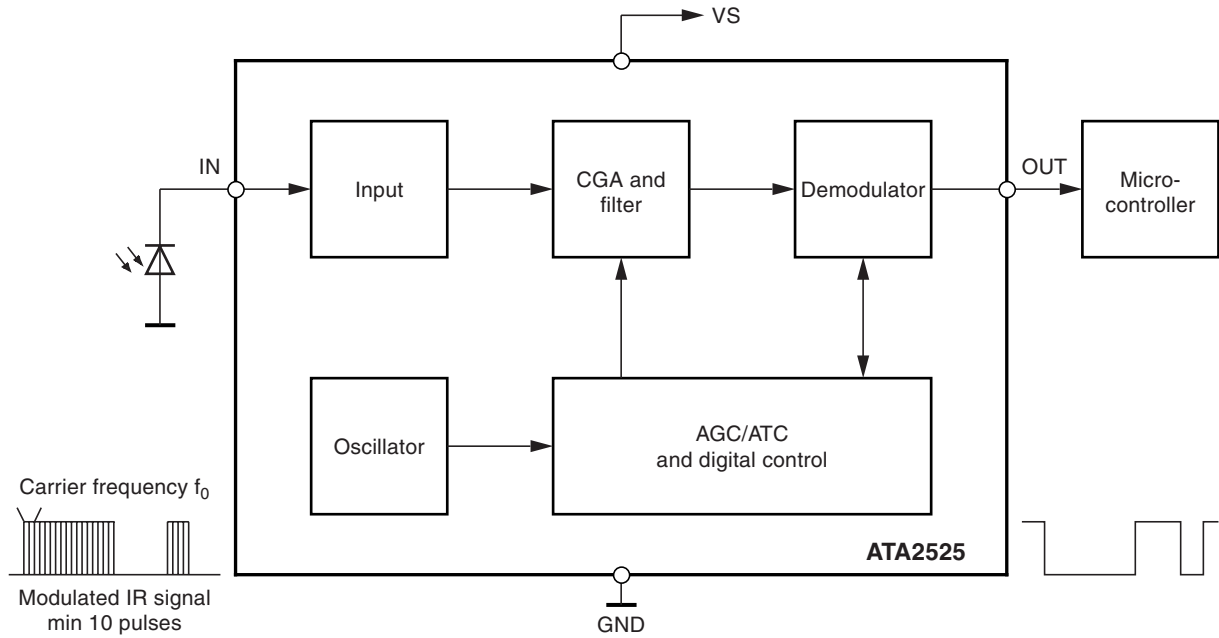

2. Absolute Maximum Ratings

Stresses beyond those listed under “Absolute Maximum Ratings” may cause permanent damage to the device. This is a stress rating only and functional operation of the device at these or any other conditions beyond those indicated in the operational sections of this specification is not implied. Exposure to absolute maximum rating conditions for extended periods may affect device reliability.

Parameters	Symbol	Value	Unit
Supply voltage	V_S	-0.3 to +6	V
Supply current	I_S	3	mA
Input voltage	V_{IN}	-0.3 to V_S	V
Input DC current at $V_S = 5V$	I_{IN}	0.75	mA
Output voltage	V_O	-0.3 to V_S	V
Output current	I_O	10	mA
Operating temperature	T_{amb}	-25 to +85	°C
Storage temperature	T_{stg}	-40 to +125	°C
Power dissipation at $T_{amb} = 25^\circ C$	P_{tot}	30	mW

3. Thermal Resistance

Parameter	Symbol	Value	Unit
Junction ambient TSSOP8	R_{thJA}	110	K/W

4. Electrical Characteristics

$T_{amb} = -25^\circ C$ to $+85^\circ C$, $V_S = 4.5V$ to $5.5V$ unless otherwise specified.

No.	Parameters	Test Conditions	Pin	Symbol	Min.	Typ.	Max.	Unit	Type*
1	Supply								
1.1	Supply-voltage range		1	V_S	4.5	5	5.5	V	C
1.2	Supply current	$I_{IN} = 0$	1	I_S	0.8	1.1	1.4	mA	B
2	Output								
2.1	Internal pull-up resistor	$T_{amb} = 25^\circ C$; see Figure 6-7 on page 8	1,3	R_{PU}		40		k Ω	A
2.2	Output voltage low	$I_L = 2$ mA; see Figure 6-7 on page 8	3,6	V_{OL}			250	mV	B
2.3	Output voltage high	$T_{amb} = 25^\circ C$	3,1	V_{OH}	$V_S - 0.25$		V_S	V	A
2.4	Output current clamping	$R_2 = 0$; see Figure 6-7 on page 8	3,6	I_{OCL}		8		mA	B
3	Input								
3.1	Input DC current	$V_{IN} = 0$; see Figure 6-7 on page 8	5	I_{IN_DCMAX}	-85			μA	C
3.2	Input DC current; Figure 6-1 on page 5	$V_{IN} = 0$; $V_S = 5V$, $T_{amb} = 25^\circ C$	5	I_{IN_DCMAX}	-530	-960		μA	B

*) Type means: A = 100% tested, B = 100% correlation tested, C = Characterized on samples, D = Design parameter

- Notes:
- BER = Bit Error Rate; e.g., BER = 5% means that with $P = 20$ at the input pin 19...21 pulses can appear at the pin OUT
 - After transformation of input current into voltage

4. Electrical Characteristics (Continued)

$T_{amb} = -25^{\circ}\text{C}$ to $+85^{\circ}\text{C}$, $V_S = 4.5\text{V}$ to 5.5V unless otherwise specified.

No.	Parameters	Test Conditions	Pin	Symbol	Min.	Typ.	Max.	Unit	Type*
3.3	Minimum detection threshold current; Figure 6-2 on page 5	Test signal: see Figure 6-6 on page 7 $V_S = 5\text{V}$, $T_{amb} = 25^{\circ}\text{C}$, $I_{IN_DC} = 1\ \mu\text{A}$; square pp, burst $N = 16$, $f = f_0$; $t_{PER} = 10\ \text{ms}$, Figure 6-6 on page 7 ; $\text{BER} = 50^{(1)}$	3	I_{Eemin}		-600		pA	B
3.4	Minimum detection threshold current with AC current disturbance $I_{IN_AC100} = 3\ \mu\text{A}$ at 100 Hz	Test signal: see Figure 6-6 on page 7 $V_S = 5\text{V}$, $T_{amb} = 25^{\circ}\text{C}$, $I_{IN_DC} = 1\ \mu\text{A}$; square pp, burst $N = 16$, $f = f_0$; $t_{PER} = 10\ \text{ms}$, Figure 6-6 on page 7 ; $\text{BER} = 50\%^{(1)}$	3	I_{Eemin}		-850		pA	C
3.5	Maximum detection threshold current	Test signal: see Figure 6-6 on page 7 $V_S = 5\text{V}$, $T_{amb} = 25^{\circ}\text{C}$, $I_{IN_DC} = 1\ \mu\text{A}$; square pp, burst $N = 16$, $f = f_0$; $t_{PER} = 10\ \text{ms}$, Figure 6-6 on page 7 ; $\text{BER} = 5\%^{(1)}$	3	I_{Eemax}	-400			μA	D
4	Controlled Amplifier and Filter								
4.1	Maximum value of variable gain (CGA)	$V_S = 5\text{V}$, $T_{amb} = 25^{\circ}\text{C}$		G_{VARMAX}		51		dB	D
4.2	Minimum value of variable gain (CGA)	$V_S = 5\text{V}$, $T_{amb} = 25^{\circ}\text{C}$		G_{VARMIN}		-5		dB	D
4.3	Total internal amplification ⁽²⁾	$V_S = 5\text{V}$, $T_{amb} = 25^{\circ}\text{C}$		G_{MAX}		71		dB	D
4.4	Center frequency fusing accuracy of bandpass	$V_S = 5\text{V}$, $T_{amb} = 25^{\circ}\text{C}$		f_{0_FUZE}	-3	f_0	+3	%	A
4.5	Overall accuracy center frequency of bandpass			f_0	-6.7	f_0	+4.1	%	C
4.6	BPF bandwidth	-3 dB; $f_0 = 38\ \text{kHz}$; see Figure 6-4 on page 6		B		3.5		kHz	B

*) Type means: A = 100% tested, B = 100% correlation tested, C = Characterized on samples, D = Design parameter

Notes: 1. BER = Bit Error Rate; e.g., BER = 5% means that with $P = 20$ at the input pin 19...21 pulses can appear at the pin OUT

2. After transformation of input current into voltage

5. Reliability

Electrical qualification (1000h at 150°C) in molded SO8 plastic package

6. Typical Electrical Curves at $T_{amb} = 25^{\circ}\text{C}$

Figure 6-1. V_{IN} versus I_{IN_DC} , $V_S = 5V$

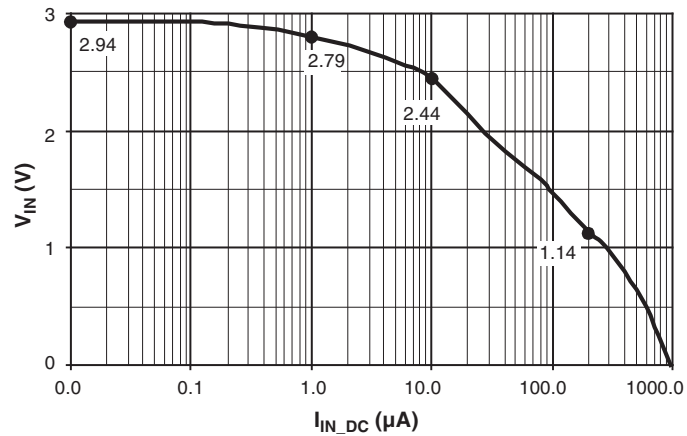

Figure 6-2. I_{Eemin} versus I_{IN_DC} , $V_S = 5V$

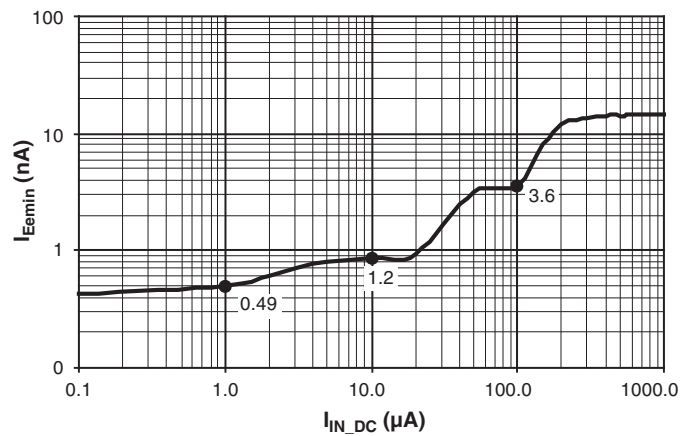

Figure 6-3. Data Transmission Rate, $V_S = 5V$

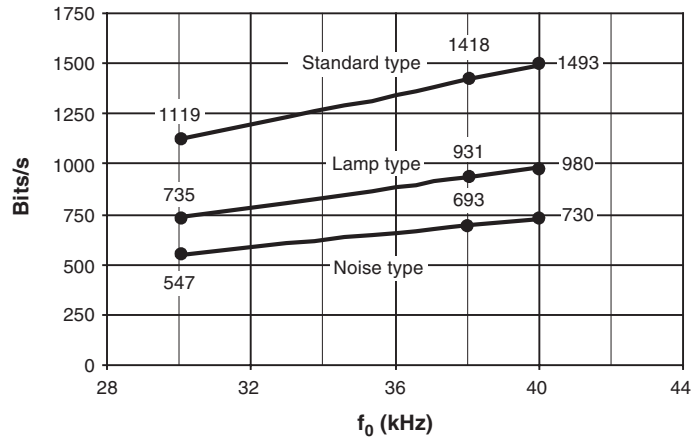
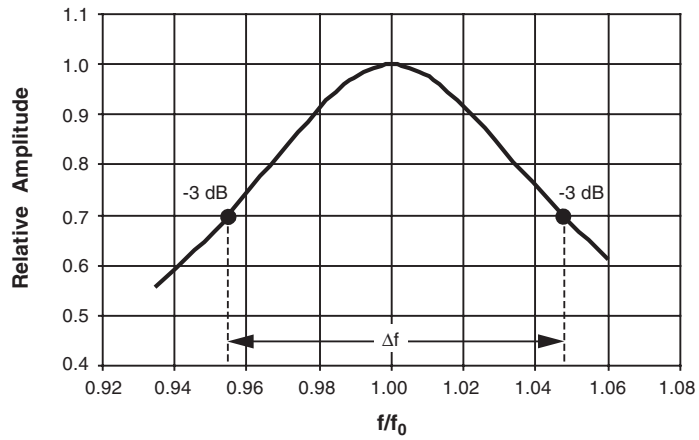
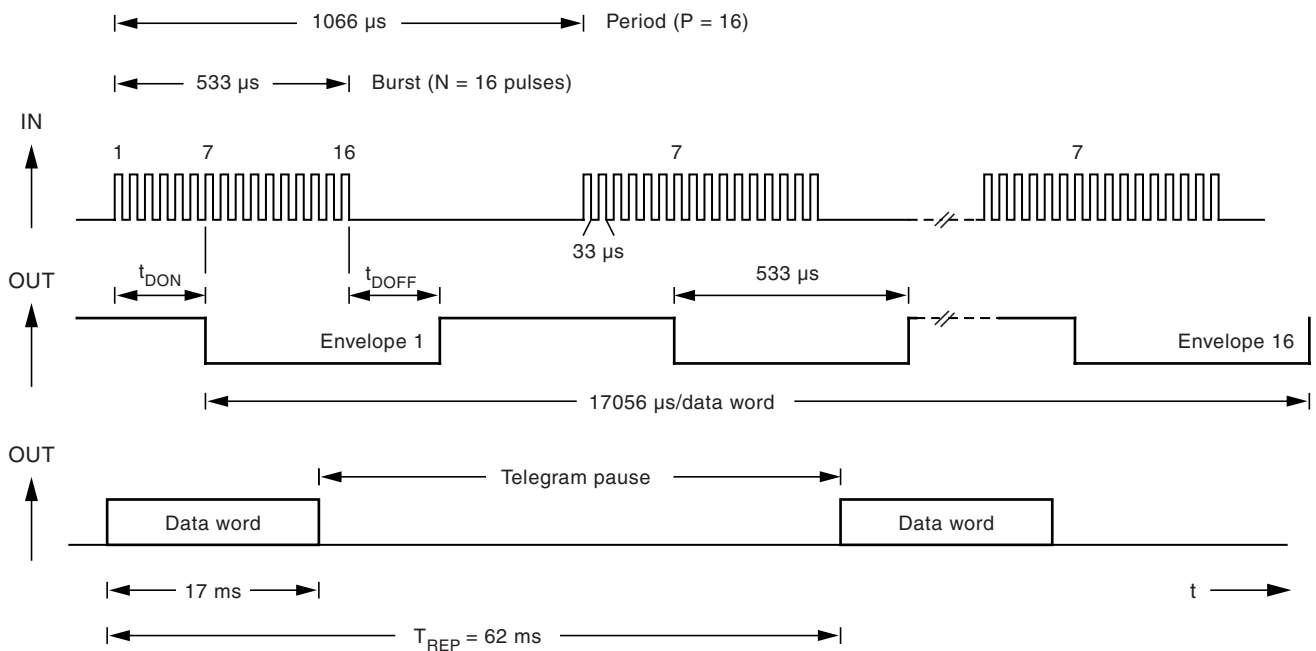

Figure 6-4. Typical Bandpass Curve



$Q = f_0/\Delta f$; $\Delta f = -3 \text{ dB values}$. Example: $Q = 1/(1.047 - 0.954) = 11$

Figure 6-5. Illustration of Used Terms



Example: $f = 30 \text{ kHz}$, burst with 16 pulses, 16 periods

Figure 6-6. Test Circuit

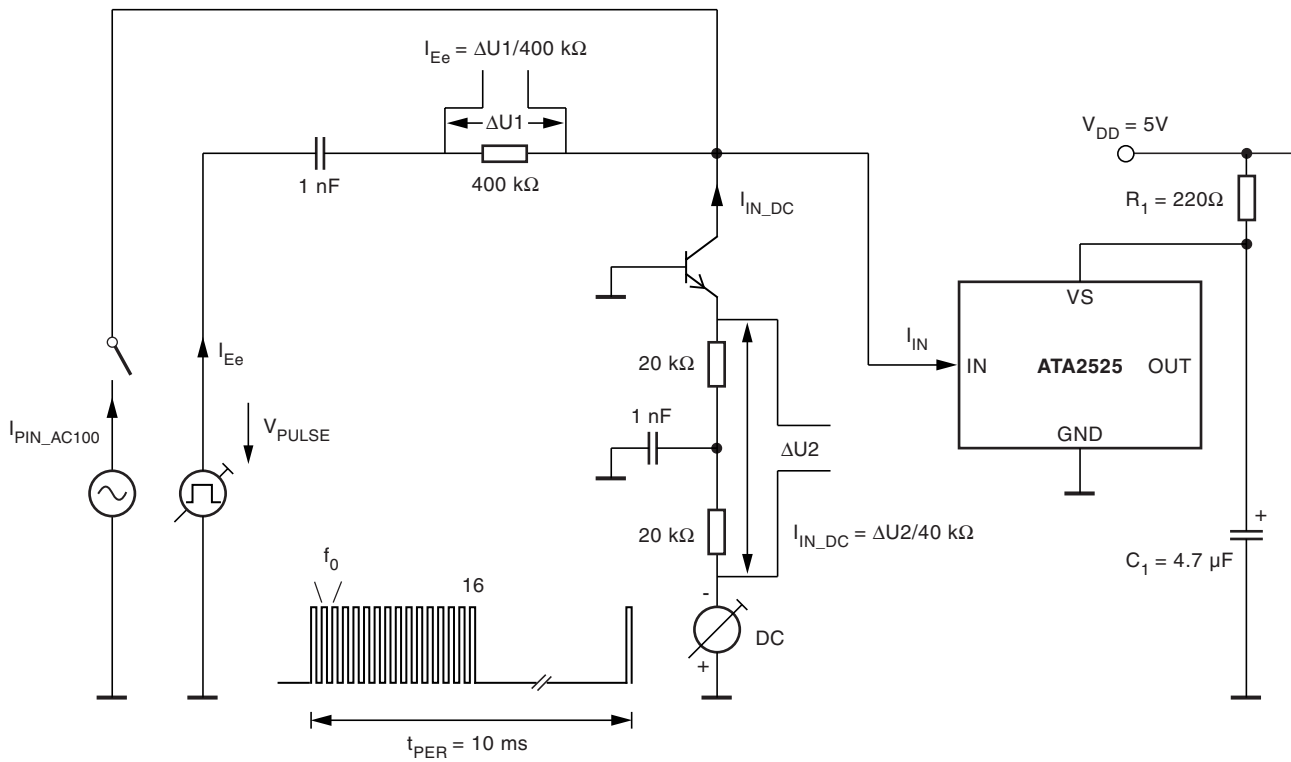
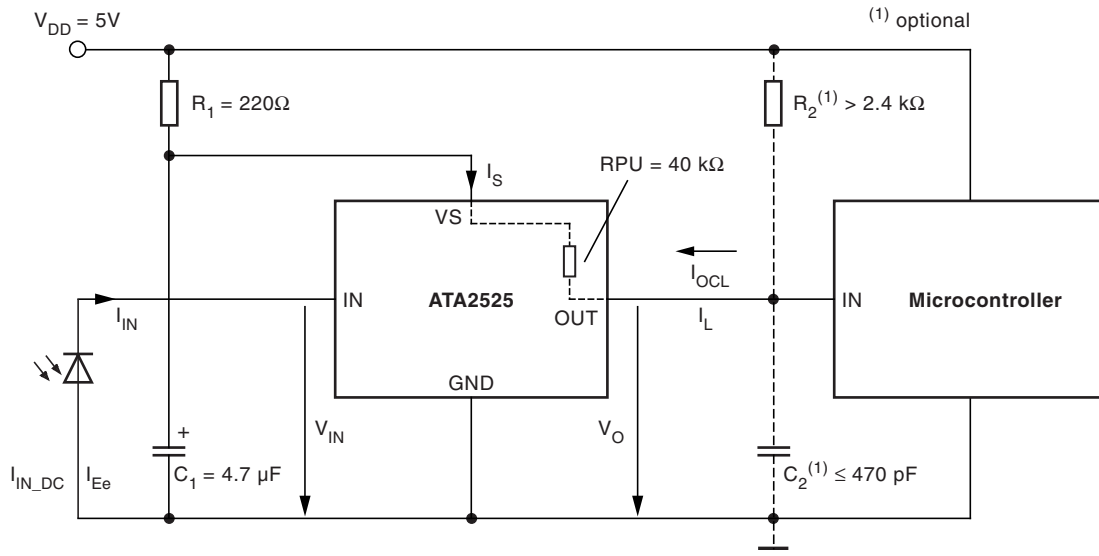
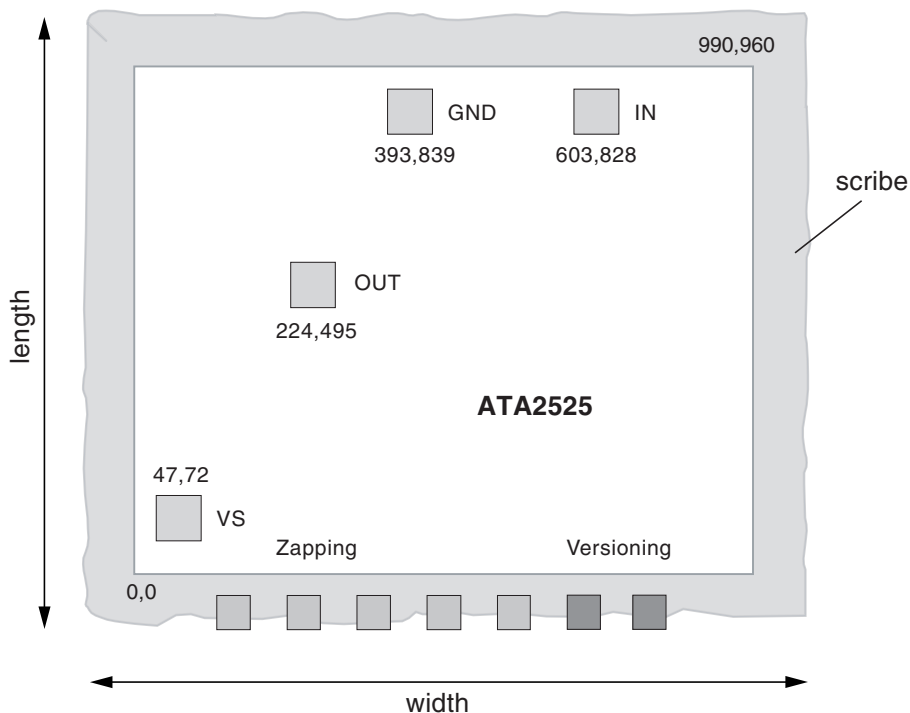

Figure 6-7. Application Circuit



7. Chip Dimensions

Figure 7-1. Chip Size in μm



Note: Pad coordinates are for lower left corner of the pad in μm from the origin 0,0

Dimensions	Length inclusive scribe	1.04 mm
	Width inclusive scribe	1.11 mm
	Thickness	$290\mu \pm 5\%$
	Pads	$80\mu \times 80\mu$
	Fusing pads	$60\mu \times 60\mu$
Pad metallurgy	Material	$\text{AlCu/AlSiTi}^{(1)}$
	Thickness	$0.8 \mu\text{m}$
Finish	Material	$\text{Si}_3\text{N}_4/\text{SiO}_2^{(1)}$
	Thickness	$0.7/0.3 \mu\text{m}$

Note: 1. Value depends on manufacture location.

8. Ordering Information

Delivery: unsawn wafers (DDW) in box

Extended Type Number	D ⁽²⁾	Type
ATA2525R1xx ⁽¹⁾ -DDW	1493	Standard type: high data rate
ATA2525R3xx ⁽¹⁾ -DDW	980	Lamp type: enhanced suppression of disturbances, secure data transmission
ATA2525R5xx ⁽¹⁾ -DDW	730	Noise type: best suppression of disturbances, low data rate

- Notes:
- xx means the used carrier frequency value (33, 36, 37, 38 or 40 kHz)
 - Maximum data transmission rate up to bits/s with $f_0 = 40$ kHz, $V_S = 5$ V (see [Figure 6-2 on page 5](#))

9. Pad Layout

Figure 9-1. Pad Layout

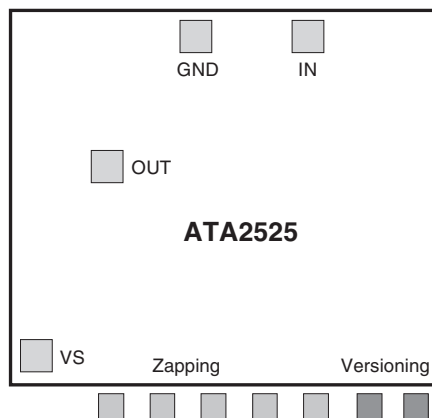

Table 9-1. Pin Description

Symbol	Function
OUT	Data output
VS	Supply voltage
GND	GND
IN	Input pin diode
Zapping	f_0 adjust
Versioning	type adjust

10. Revision History

Please note that the following page numbers referred to in this section refer to the specific revision mentioned, not to this document.

Revision No.	History
4854E-AUTO-10/06	<ul style="list-style-type: none">• Features on page 1 changed• Applications on page 1 changed• Section 1 "Description" on page 1 changed• Section 2 "Pin Configuration" on page 2 deleted• Section 4 "Electrical Characteristics" number 3.3 on page 4 changed• Section 4 "Electrical Characteristics" number 3.4 on page 4 changed• Section 6 "ESD" on page 5 deleted• Section 10 "Ordering Information" on page 10 changed
4854D-AUTO-04/06	<ul style="list-style-type: none">• Put datasheet in a new template• Section 10 "Ordering Information" on page 10 changed



Atmel Corporation

2325 Orchard Parkway
San Jose, CA 95131, USA
Tel: 1(408) 441-0311
Fax: 1(408) 487-2600

Regional Headquarters

Europe

Atmel Sarl
Route des Arsenaux 41
Case Postale 80
CH-1705 Fribourg
Switzerland
Tel: (41) 26-426-5555
Fax: (41) 26-426-5500

Asia

Room 1219
Chinachem Golden Plaza
77 Mody Road Tsimshatsui
East Kowloon
Hong Kong
Tel: (852) 2721-9778
Fax: (852) 2722-1369

Japan

9F, Tonetsu Shinkawa Bldg.
1-24-8 Shinkawa
Chuo-ku, Tokyo 104-0033
Japan
Tel: (81) 3-3523-3551
Fax: (81) 3-3523-7581

Atmel Operations

Memory

2325 Orchard Parkway
San Jose, CA 95131, USA
Tel: 1(408) 441-0311
Fax: 1(408) 436-4314

Microcontrollers

2325 Orchard Parkway
San Jose, CA 95131, USA
Tel: 1(408) 441-0311
Fax: 1(408) 436-4314

La Chantrerie
BP 70602
44306 Nantes Cedex 3, France
Tel: (33) 2-40-18-18-18
Fax: (33) 2-40-18-19-60

ASIC/ASSP/Smart Cards

Zone Industrielle
13106 Rousset Cedex, France
Tel: (33) 4-42-53-60-00
Fax: (33) 4-42-53-60-01

1150 East Cheyenne Mtn. Blvd.
Colorado Springs, CO 80906, USA
Tel: 1(719) 576-3300
Fax: 1(719) 540-1759

Scottish Enterprise Technology Park
Maxwell Building
East Kilbride G75 0QR, Scotland
Tel: (44) 1355-803-000
Fax: (44) 1355-242-743

RF/Automotive

Theresienstrasse 2
Postfach 3535
74025 Heilbronn, Germany
Tel: (49) 71-31-67-0
Fax: (49) 71-31-67-2340

1150 East Cheyenne Mtn. Blvd.
Colorado Springs, CO 80906, USA
Tel: 1(719) 576-3300
Fax: 1(719) 540-1759

Biometrics/Imaging/Hi-Rel MPU/ High-Speed Converters/RF Datacom

Avenue de Rochepleine
BP 123
38521 Saint-Egreve Cedex, France
Tel: (33) 4-76-58-30-00
Fax: (33) 4-76-58-34-80

Literature Requests

www.atmel.com/literature

Disclaimer: The information in this document is provided in connection with Atmel products. No license, express or implied, by estoppel or otherwise, to any intellectual property right is granted by this document or in connection with the sale of Atmel products. **EXCEPT AS SET FORTH IN ATMEL'S TERMS AND CONDITIONS OF SALE LOCATED ON ATMEL'S WEB SITE, ATMEL ASSUMES NO LIABILITY WHATSOEVER AND DISCLAIMS ANY EXPRESS, IMPLIED OR STATUTORY WARRANTY RELATING TO ITS PRODUCTS INCLUDING, BUT NOT LIMITED TO, THE IMPLIED WARRANTY OF MERCHANTABILITY, FITNESS FOR A PARTICULAR PURPOSE, OR NON-INFRINGEMENT. IN NO EVENT SHALL ATMEL BE LIABLE FOR ANY DIRECT, INDIRECT, CONSEQUENTIAL, PUNITIVE, SPECIAL OR INCIDENTAL DAMAGES (INCLUDING, WITHOUT LIMITATION, DAMAGES FOR LOSS OF PROFITS, BUSINESS INTERRUPTION, OR LOSS OF INFORMATION) ARISING OUT OF THE USE OR INABILITY TO USE THIS DOCUMENT, EVEN IF ATMEL HAS BEEN ADVISED OF THE POSSIBILITY OF SUCH DAMAGES.** Atmel makes no representations or warranties with respect to the accuracy or completeness of the contents of this document and reserves the right to make changes to specifications and product descriptions at any time without notice. Atmel does not make any commitment to update the information contained herein. Unless specifically provided otherwise, Atmel products are not suitable for, and shall not be used in, automotive applications. Atmel's products are not intended, authorized, or warranted for use as components in applications intended to support or sustain life.

© 2006, Atmel Corporation. All rights reserved. Atmel®, logo and combinations thereof, Everywhere You Are® and others are registered trademarks or trademarks of Atmel Corporation or its subsidiaries. Other terms and product names may be trademarks of others.